

Service Manual

 **Technics**

HI-FI COMPONENTS

 **Technics**



MODEL **SL-1300**

SPECIFICATIONS

TURNTABLE SECTION

Type:	Automatic player system with MEMO-REPEAT
Driving method:	Direct drive
Turntable Plater:	Aluminium die-cast; 33 cm (13") diameter 250 kg-cm ² (86.2 lb-in ²) inertial moment, 1.65 kg (3.7 lb) weight
Turntable Speeds:	33-1/3 and 45 r.p.m.
Motor:	Ultra low-speed brushless DC motor
Power Supply:	50/60 Hz AC 110V/120/220/240V, 4W
Speed Change Method:	Electronical change
Variable Pitch Control:	Individual adjustment by variable resistor, 10% adjustment range
Wow and Flutter:	Less than 0.03% WRMS
Rumble:	-50dB (DINA), -70 dB (DIN B)
Build-up Time:	Within 1/2 rotation at 33-1/3 r.p.m.
Dimensions:	(W) 45.3cm x (D) 36.6cm x (H) 13.9cm (17-13/16" x 14-13/32" x 5-1/2")
Weight:	9.4 kg (20.7 lb)

TONARM SECTION

Type:	Universal "S" shaped pipe arm, static-balanced type, direct reading stylus pressure adjustment with, anti-skating force control device, cueing device.
Effective Length:	230 mm (9-1/16")
Overhang:	15 mm (19/32")
Tracking Error Angle:	Within $\pm 3^\circ$ (at the point 150 mm (5-1/8") from the center)
Stylus Pressure:	0 - 3 g

(Specifications, design and other details are subject to change, without prior notice, at any time in order to improve performance)

MATSUSHITA ELECTRIC
MATSUSHITA ELECTRIC TRADING CO., LTD.
P. O. Box 288, Central Osaka, Japan

OPERATING PRINCIPLES

1. Starting operation (Figure 1)

- 1-1. Pull the start/stop lever in the direction shown by the arrow A to the "START" position.
- 1-2. The start cam will then rotate, and start plates A and B will slide in the direction shown by the arrow D.
- 1-3. The projection on start plate B causes the repeat cam to rotate in the direction shown by the arrow E.
At this time, the knob indication becomes "1".
- 1-4. The movement of the repeat cam causes the start setting plate to slide in the direction shown by the arrow F.
- 1-5. The start setting plate causes the switch lever to rotate in the direction shown by the arrow G.
- 1-6. The switch lever causes the switch button to be pushed in the direction shown by the arrow M. At this time, the switch is in the on position.
- 1-7. The strobo-light illuminates and the turntable rotates in the direction shown by the arrow J.
- 1-8. At the same time that the start cam rotates, the cut plate moves in the direction shown by arrow C.
- 1-9. The actuating plate spring is pressed by the tip of the cut plate and the actuating plate rotates in the direction shown by the arrow H.
- 1-10. The movement of the tip of the actuating plate causes the friction link and the actuating link to rotate in the direction shown by the arrow I.
- 1-11. The tip of the actuating link is pressed by the pinion shown by the arrow N. Thus, the pinion and the main gear are interlocked.

2. Drive operation (Figure 2)

- 2-1. The main gear rotates in the direction shown by the arrow N, and the operating plate slides in the direction shown by the arrow O, due to the action of the cam.
- 2-2. The arm lift is raised by the arm lift cam causing the stylus of the tonearm to be lifted.
- 2-3. The actuating plate spring is pressed by the actuating plate resetting pin, causing the actuating plate to move back in the direction shown by the arrow Q.
- 2-4. Because the repeat pawl spring is extended, the repeat pawl latches over a tooth of the ratchet wheel for the repeat cam.
- 2-5. The tip of the control latch for the tonearm contacts the start setting plate and rotates in the direction shown by the arrow P, placing the operating pin for the tonearm in between the notch of the steel ball with the spring for the control latch supporting it.

3. Tonearm movement operation (Figure 3)

- 3-1. In the elongated hole of the operating plate, the index moves in the direction shown by the arrow Z.
- 3-2. The bent portion of the index contacts the step portion of the select lever.
 - a) When the indication of the selector knob is at 30 cm, the bent portion of the index contacts step "a" of the select lever.
 - b) When the indication of the selector knob is at 25 cm, the bent portion of the index contacts step "b" of the select lever.
 - c) When the indication of the selector knob is at 17 cm, the bent portion of the index contacts step "c" of the select lever.
- 3-3. The main gear rotates further and the operating plate slides in the direction shown by the arrow R, due to the action of the cam.
- 3-4. The control latch for the tonearm pushes the operating pin for tonearm, causing the tonearm to move in the direction shown by the arrow L.
- 3-5. The bent portion of the safety plate for the tonearm contacts the step portion of the index, causing the rotation to stop.
 - a) When the indication of the selector knob is at 30 cm, the bent portion of the safety plate contacts step "f" of the index.
 - b) When the indication of the selector knob is at 25 cm, the bent portion of the safety plate contacts step "e" of the index.
 - c) When the indication of the selector knob is at 17 cm, the bent portion of the safety plate contacts step "d" of the index.
- 3-6. The control latch for the tonearm moves, in the direction shown by the arrow U, out of the track of the operating pin for the tonearm.

- 3-7. The repeat pawl moves the ratchet wheel of the repeat cam in the direction shown by the arrow S, and the indication of the repeat knob becomes O.
- 3-8. The start setting plate is returned by the repeat cam.
The switch lever is supported by the cam portion of the switch lever and the slide latch, and the switch is maintained in the ON condition.
- 3-9. The operating plate moves the index plate, in the direction shown by the arrow T, out of the track of the safety plate for the tonearm.
- 3-10. While the main gear is rotating, the actuating link and the friction link are returned by the pinion.

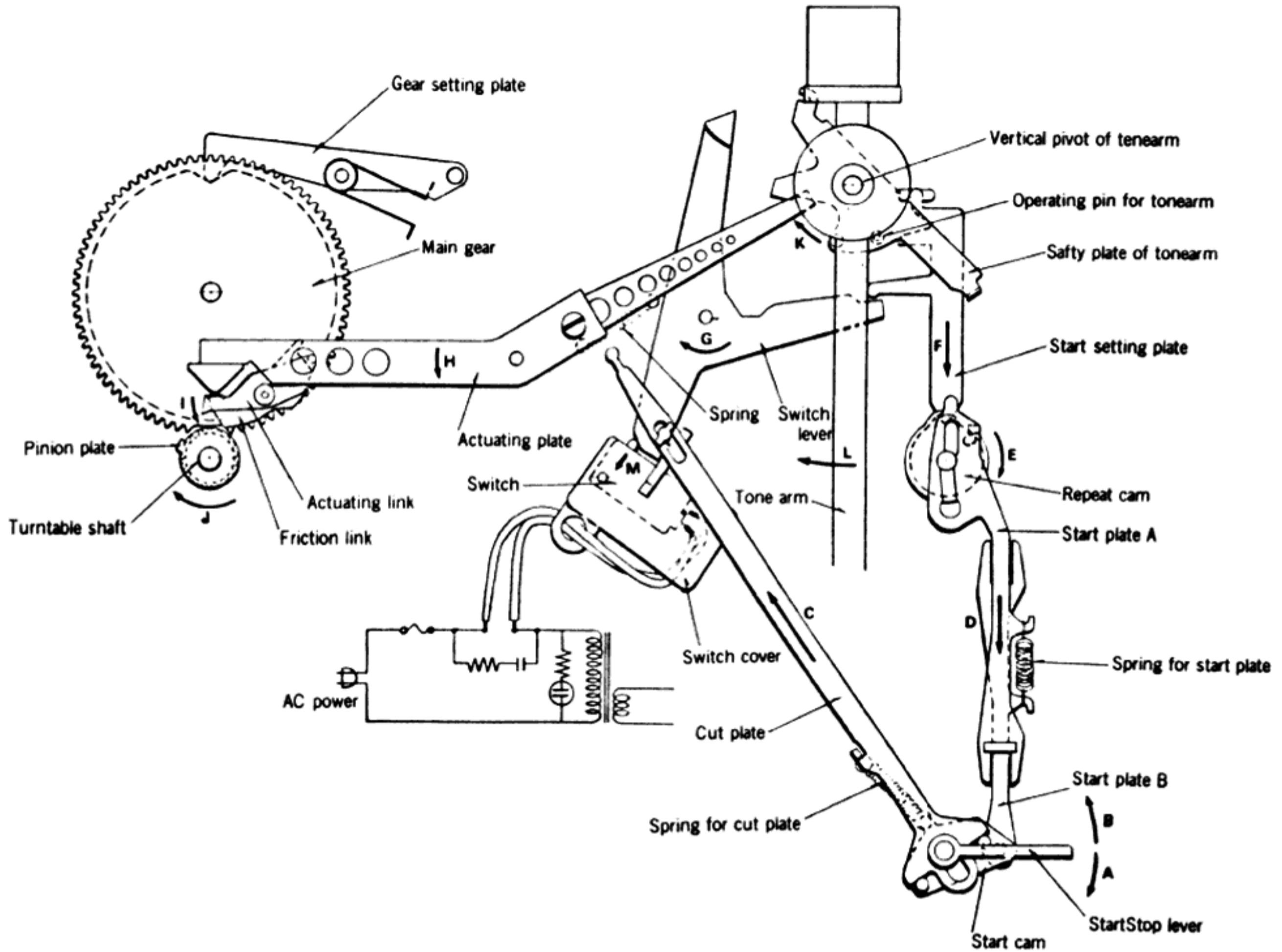

Fig. 1

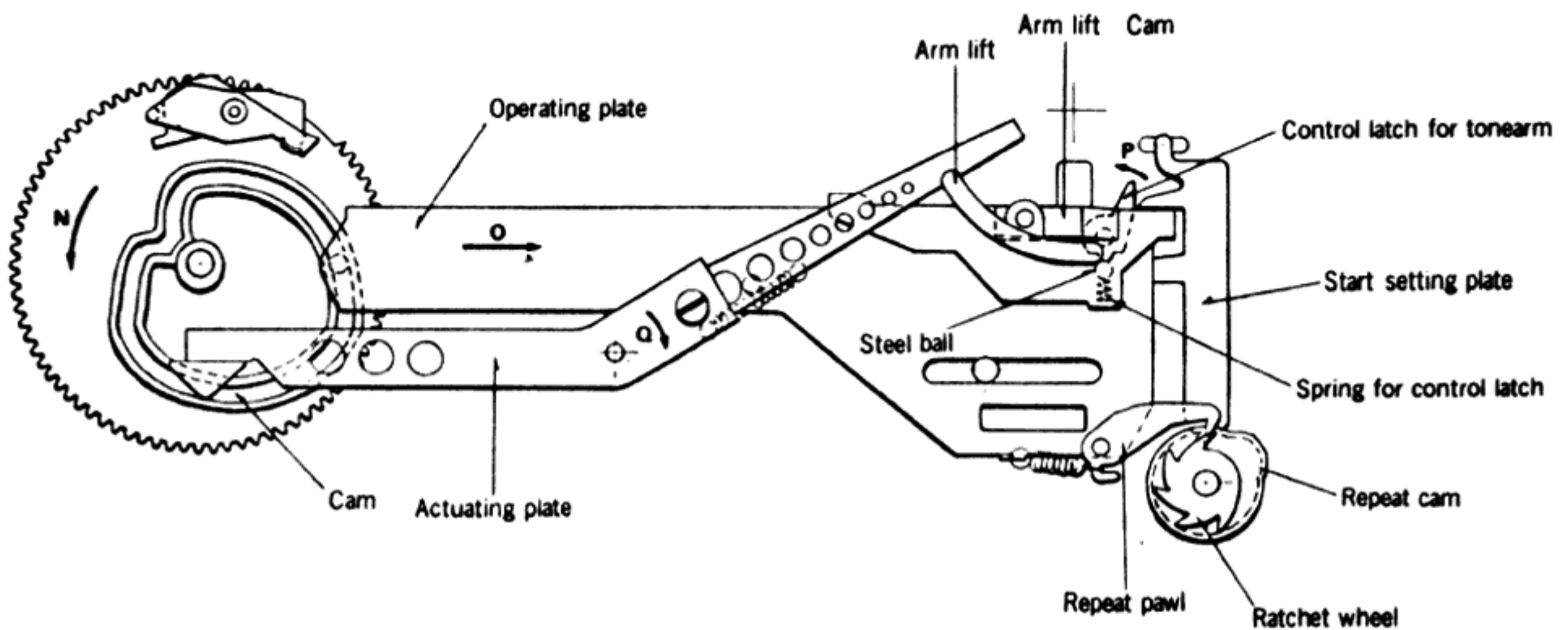

Fig. 2

3-11. The slide latch moves out of the cam portion of the switch lever.

The switch lever is supported by the switch supporting plate and the switch is maintained in the ON condition.

3-12. The arm lift cam causes the arm lift to be lowered. Thus, the tonearm stylus contacts the record surface.

3-13. The portion of the main gear where there are no teeth is stopped due to the gear setting lever at the location corresponding to the pinion.

3-14. Play is started.

4. Auto-return operation (Figure 1) (Figure 4)

4-1. When the tonearm moves to the center of the record according to the record performance, the operating pin for the tonearm pushes the actuating plate in the direction indicated by the arrow K.

4-2. The actuating plate rotates in the direction shown by the arrow H. Then it pushes the friction link.

4-3. The actuating link on the friction link also rotates in the direction shown by the arrow I.

4-4. If the movement of the tonearm in the groove of the record is small, the actuating link is pushed at the rear part of the pinion pawl, sliding from the friction link.

4-5. When the performance reaches the end, the actuating link moves widely, due to the rough groove on the record.

4-6. When the actuating link is pushed by the pinion pawl, the main gear rotates in the direction shown by the arrow N. Then the main gear is meshed with the pinion.

4-7. The operating plate slides in the direction shown by the arrow O.

4-8. When the lift is raised by the lift cam, the stylus of the tonearm lifts from the record.

4-9. The actuating plate returns in the direction shown by the arrow Q.

4-10. When the operating pin for the tonearm is pushed by the operating plate, the tonearm slides in the direction shown by the arrow W, returning to the rest.

4-11. The switch supporting plate is rotated by the operating plate in the direction shown by the arrow X. The support for the switch lever is then released.

The switch lever remains in the "ON" position because the cam portion is supported by the slide latch.

4-12. The control latch for the tonearm does not contact the start setting plate, because the start setting plate has already returned.

4-13. The operating plate slides in the direction shown by the arrow R. However, the tonearm does not move from the rest.

4-14. During the time that the main gear is rotating, both the actuating link and the friction link are returned by the pinion.

4-15. When the switch lever is rotated in the direction shown by the arrow V, due to the movement of the slide latch, the power for the unit is switched off.

4-16. The tonearm is set on the rest by the lowering of the lift.

4-17. The rotation of the main gear is stopped by the gear setting plate.

5. Stop operation (Figure 1) (Figure 4)

5-1. Push the start/stop lever in the direction shown by the arrow B ("STOP").

5-2. The cut plate slides in the direction shown by the arrow C.

5-3. The actuating plate rotates in the direction shown by the arrow H, causing the actuating link to rotate in the direction shown by the arrow H.

5-4. The same operations occur that are described in 4-6 ~ 4-17 of the return operation section.

6. Manual performance (Figure 5)

6-1. Move the tonearm manually in the direction shown by the arrow L.

6-2. The switch lever is rotated in the direction shown by the arrow G, due to the switch control roller.

6-3. The switch is then on, and the turntable rotates.

6-4. The switch control roller is then released from the switch lever.

6-5. The switch lever is supported by the switch supporting plate, and the switch is maintained in the on position.

6-6. Performance begins.

6-7. When the performance reaches the end, it stops automatically due to the auto-return operation described in 4-1 ~ 4-17.

6-8. If the tonearm is manually returned to the rest during the performance, the switch supporting plate is rotated in the direction shown by the arrow X, due to the switch control roller.

6-10. The support of the switch lever is released, and then it rotates in the direction shown by the arrow V. The switch is now in the off position, turning off the power.

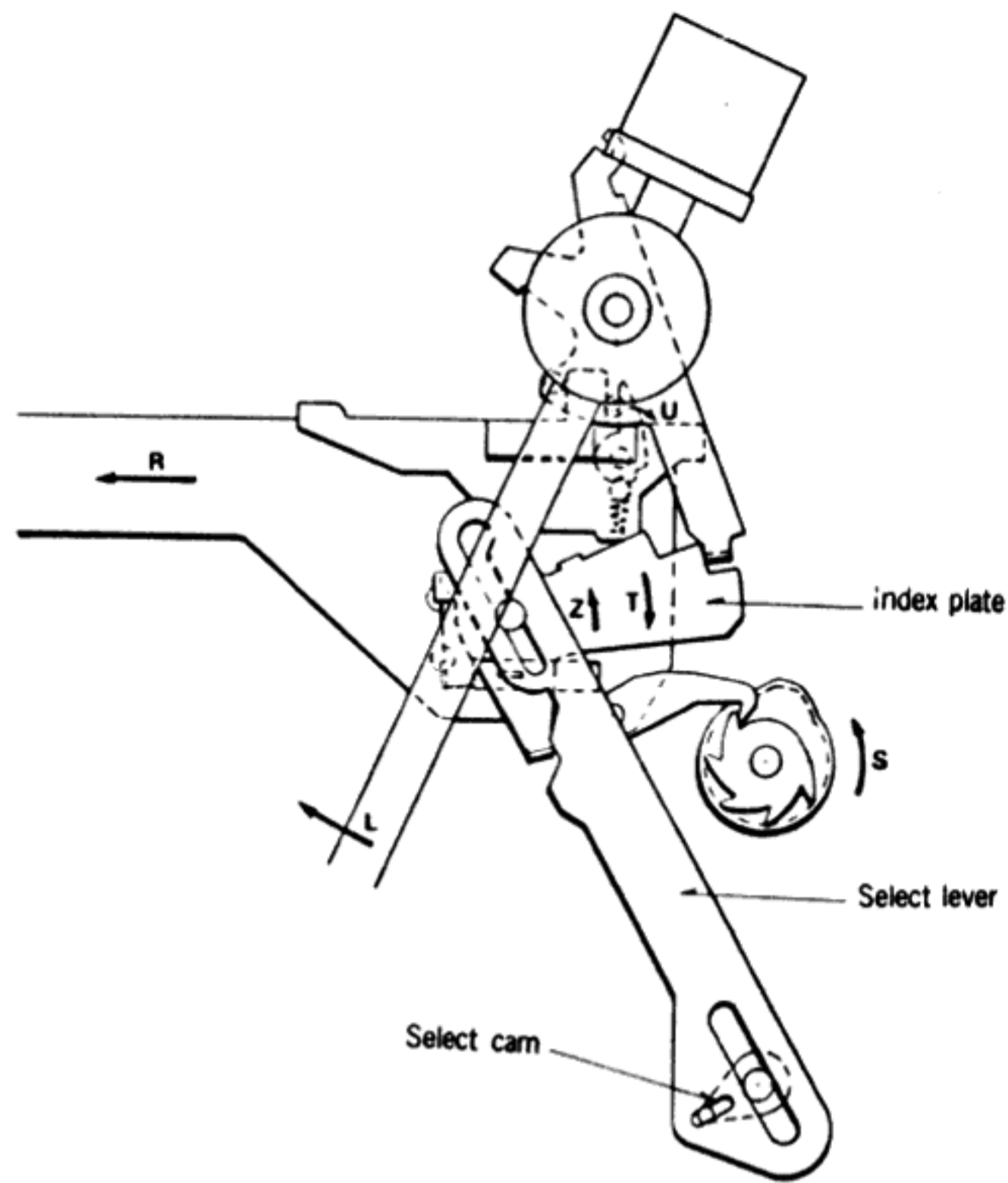

Fig. 3

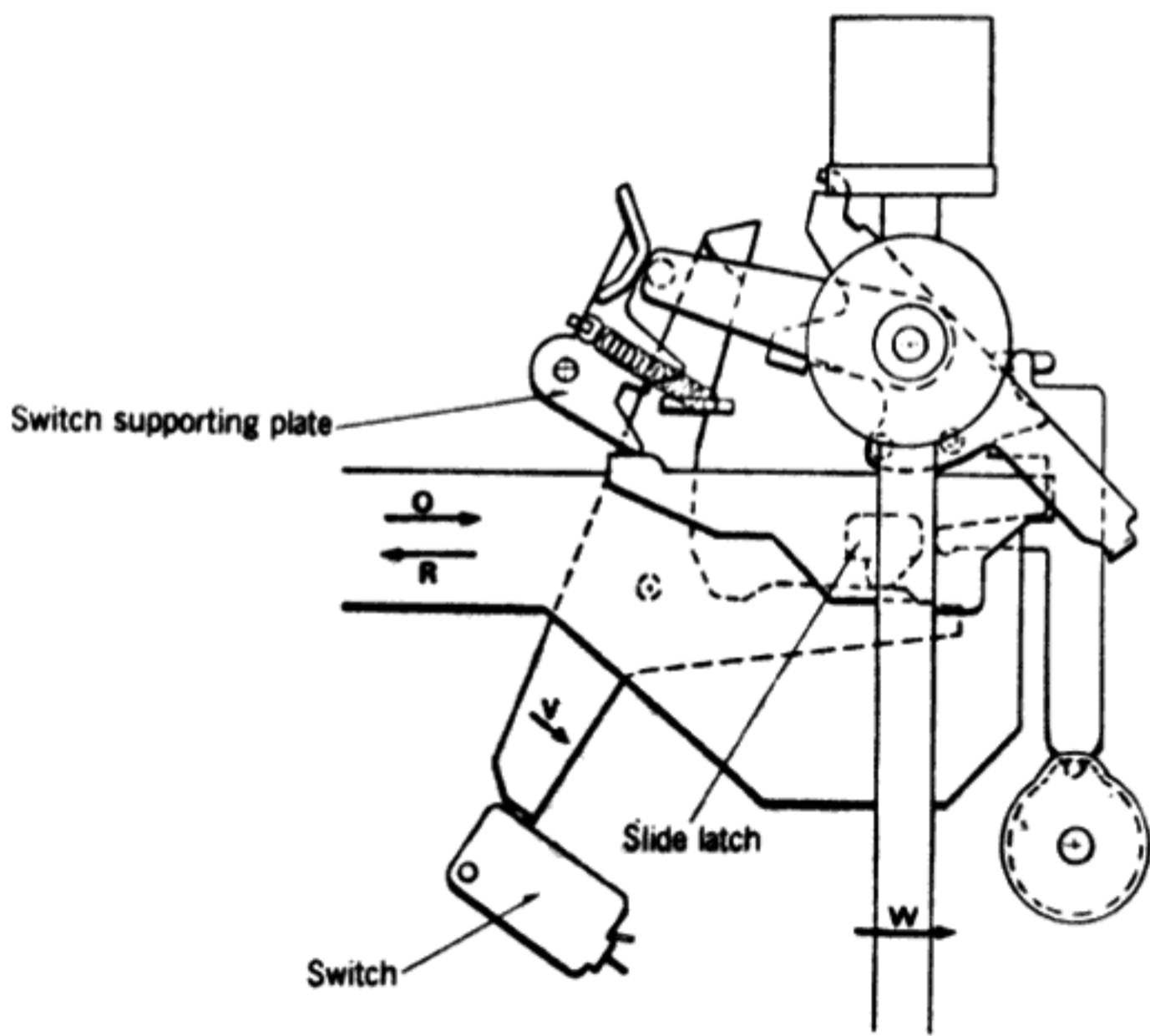

Fig. 4

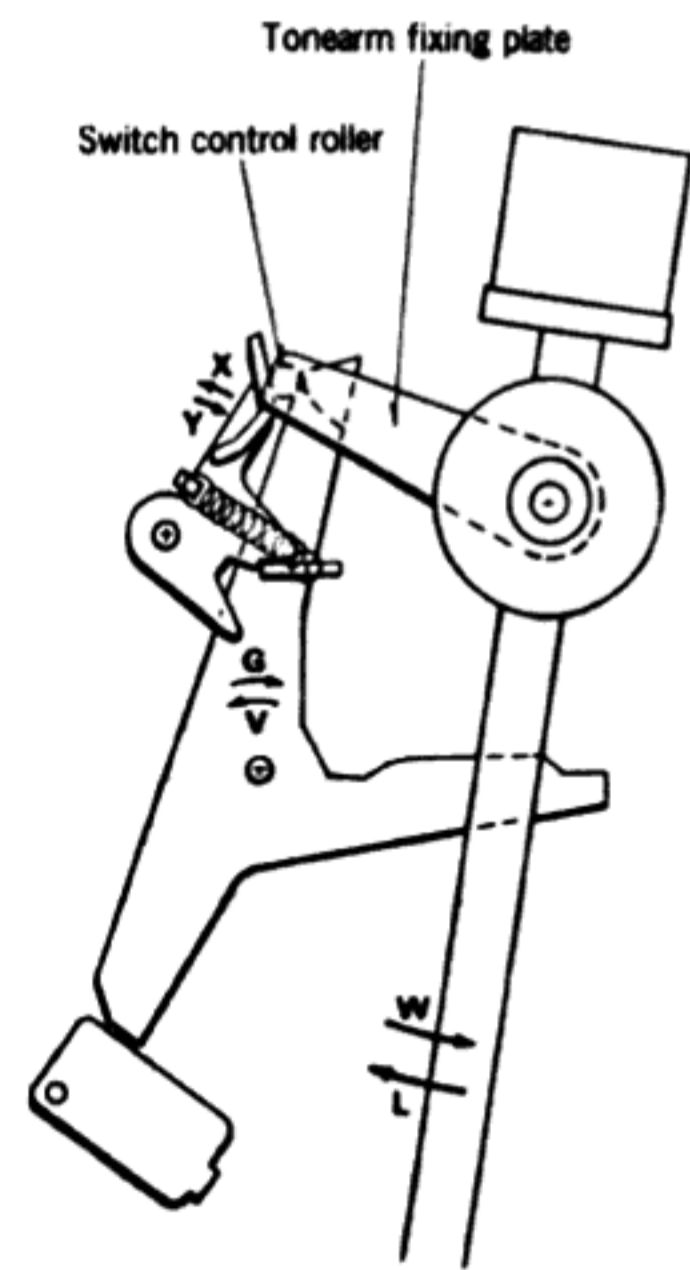

Fig. 5

7. Memory repeat operation (Figures 1 ~ 4)

- 7-1. Set the indication of the memory repeat knob to number of times to be played.
- 7-2. The start setting plate will slide in the direction shown by the arrow F, due to the operation of the repeat cam.
- 7-3. The switch lever turns in the direction shown by the arrow G, setting the switch to the on position.
- 7-4. The turntable operates.
- 7-5. Set the start/stop lever to the "START" position by moving the lever in the direction shown by the arrow A.
- 7-6. The cut plate slides in the direction shown by the arrow C.
- 7-7. The actuating plate slides, pushing the actuating link and turning the main gear.
- 7-8. The operating plate slides, raising the lift and setting the index.
- 7-9. The control latch for the tonearm contacts the start setting plate, turning in the direction shown by the arrow P.
- 7-10. The repeat pawl meshes with the ratchet wheel attached at the repeat cam, turning the ratchet wheel in the direction shown by the arrow S. By this operation, one ratchet wheel tooth at a time will return, and the number of times indicated by the repeat knob will reduce by one.
- 7-11. The tonearm turns in the direction shown by the arrow L, and its position is determined by the index.
- 7-12. The lift lowers, starting the play performance.
- 7-13. When the performance reaches the end, the main gear rotates.
- 7-14. The lift raises, and the tonearm turns in the direction shown by the arrow W.
- 7-15. The operation, as explained in 7-9 ~ 7-14, is repeated.
- 7-16. The indication of the repeat knob reaches O. The start setting plate returns to its original position.
- 7-17. The tonearm turns in the direction shown by the arrow L, and its position is determined by the index.
- 7-18. The lift lowers, starting the play performance.
- 7-19. When the performance reaches the end, the main gear rotates.
- 7-20. The lift raises, and the tonearm turns in the direction shown by the arrow W.
- 7-21. Because the control latch for the tonearm doesn't contact the start setting plate, the tonearm is left on the rest.
- 7-22. The lift lowers, setting the switch to the off position, and the turntable stops its operation.

8. Continuous repeat

- 8-1. Set the indication of the memory repeat knob to the R position.
- 8-2. The operations, as explained in 7-2 ~ 7-14, will be repeated.
As for section 7-10, when the repeat knob indicates R, the ratchet wheel attached to the repeat cam has no tooth for the repeat pawl, and R is indicated continuously.
- 8-3. The unit continues to play until the repeat knob is returned to the O position.

ADJUSTMENT INSTRUCTION

1. Variable Pitch Controls

Turn this knob clockwise or counterclockwise, as necessary, to reduce or increase the rotational speed of the turntable.

Clockwise rotation (+ direction) ... This increases the speed of the turntable platter. Rotate clockwise if the strobo dots seem to be "falling back"; i.e., seem to be moving counterclockwise. When the dots appear to be stationary, turntable speed is accurate.

Counterclockwise rotation (- direction) ... This decreases the speed of the turntable platter. Rotate counterclockwise if the dots seem to be "running ahead"; i.e., seem to be moving clockwise, until they appear stationary.

Each of the two turntable speeds (33-1/3 and 45 r.p.m.) can be adjusted within a range of 10%.

2. Speed Adjustment Screws

If, for any reason, the adjustment cannot be successfully made by the variable pitch controls, turn these screws clockwise or counterclockwise with a (-), tip screw driver.

Clockwise The rotation of the turntable platter will be slowed down.

Counterclockwise ... The rotation will be speeded up. After the adjustment has been made, the speed will not change and re-adjustment will not be necessary.

3. Tonearm Return Adjustment Screw

In some cases, the tonearm will tend to return to its rest position before the record has finished playing. In other cases, it will return to the rest position even after the record has finished. Rotation of this screw in the proper direction will correct either condition.

Clockwise rotation ...The tonearm will return to rest later.

Counterclockwise rotation...The tonearm will return to rest earlier.

4. Stylus Set-down Adjustment Screw

To be adjusted if the tonearm fails to set down at the right starting point at the beginning of the record. For access to the screw, a rubber cap above it must be removed.

Clockwise rotation ...This will move the set-down point outward, away from the record center.

Counterclockwise rotation...This will move the set-down point inward toward the record center.

5. Arm Lift Adjustment Screw

When the tonearm is removed from the record surface via the tonearm lift, the space between the stylus tip and the record surface should be between 5 and 10 mm (between 3/16" and 25/64"). If this height needs adjustment, turn the screw along the

6. Adjustment for the tonearm fixing plate

This adjustment should be made from behind the base of the tonearm and at the following times:

When the switch position is moved, causing a faulty operation.

When the play starting position cannot be adjusted.

When the tonearm fixing plate is exchanged.

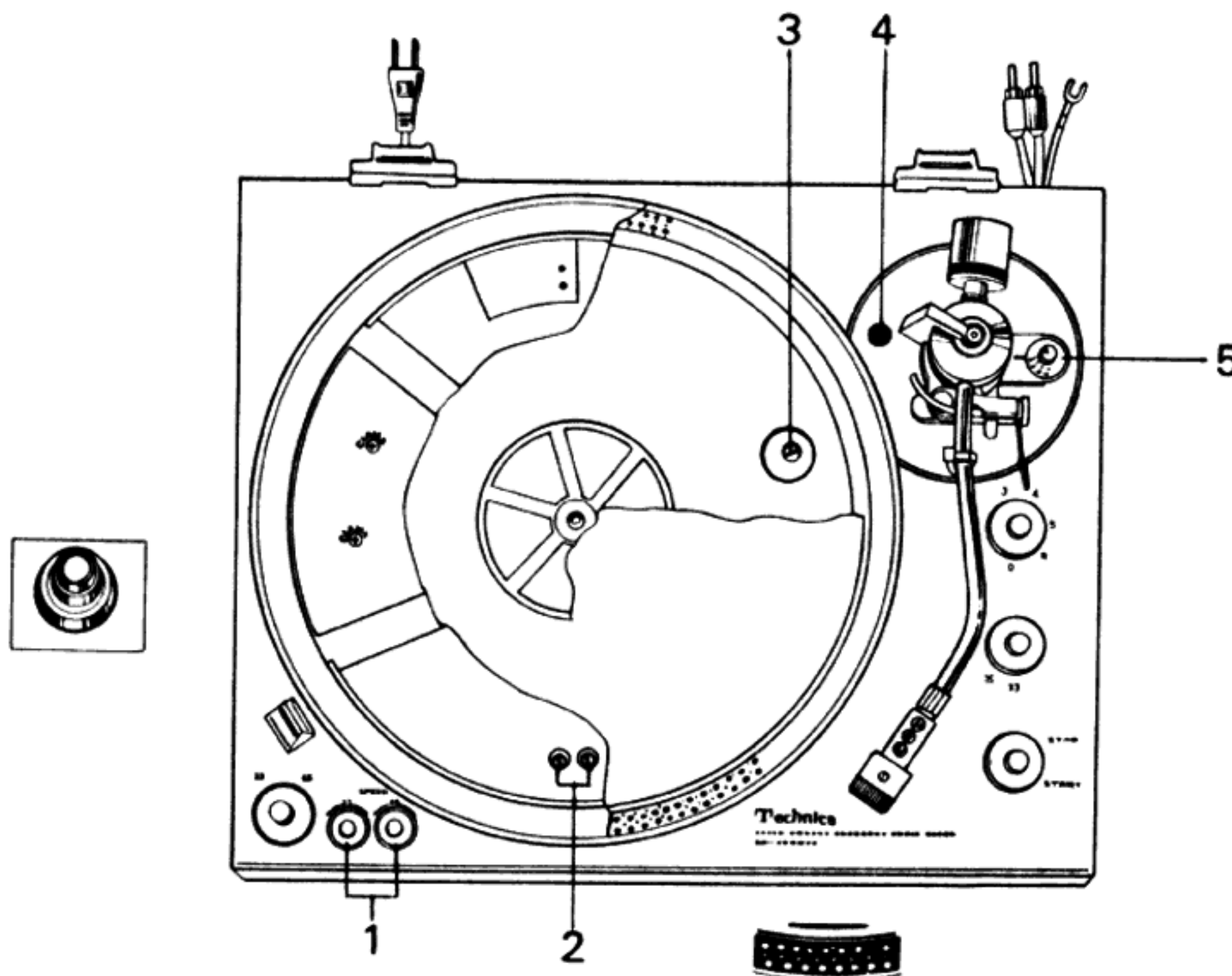
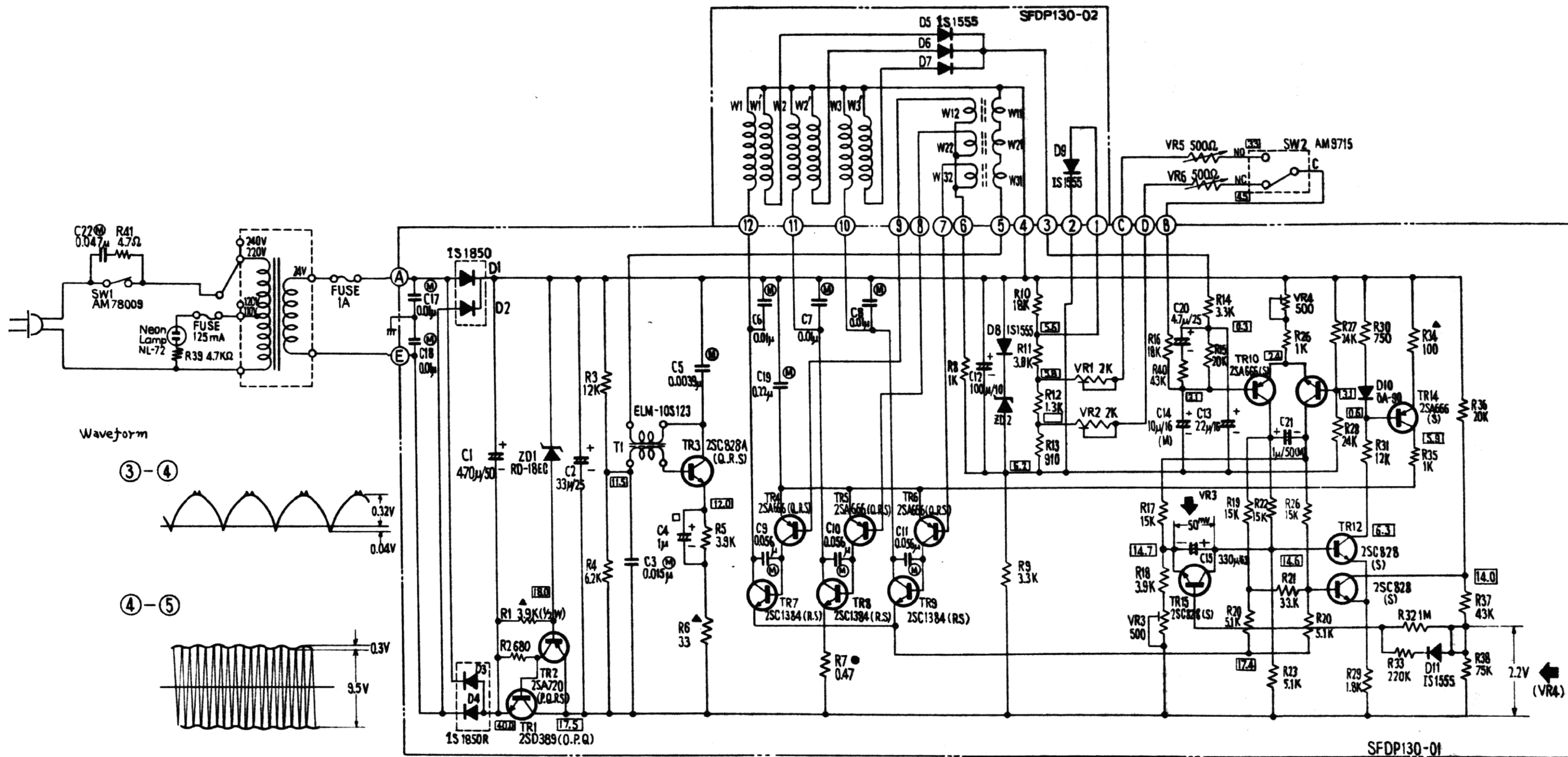

Fig. 6

SCHEMATIC DIAGRAM SL-1300



Waveform

③-④

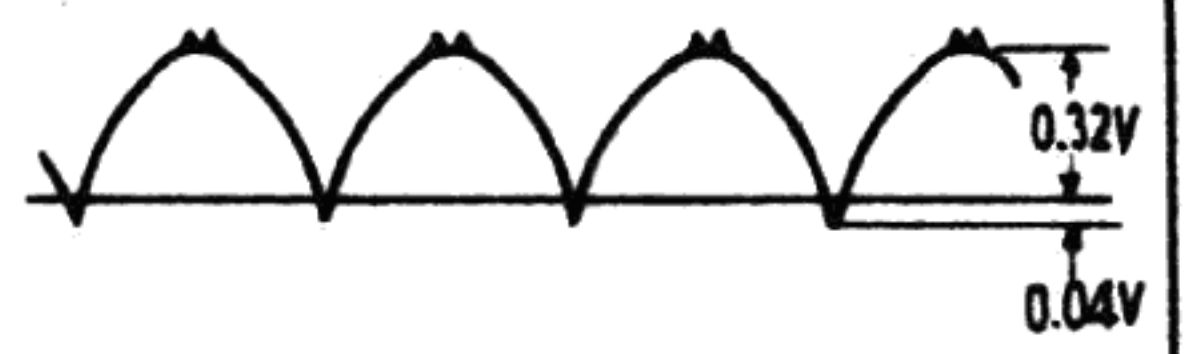

④-⑤

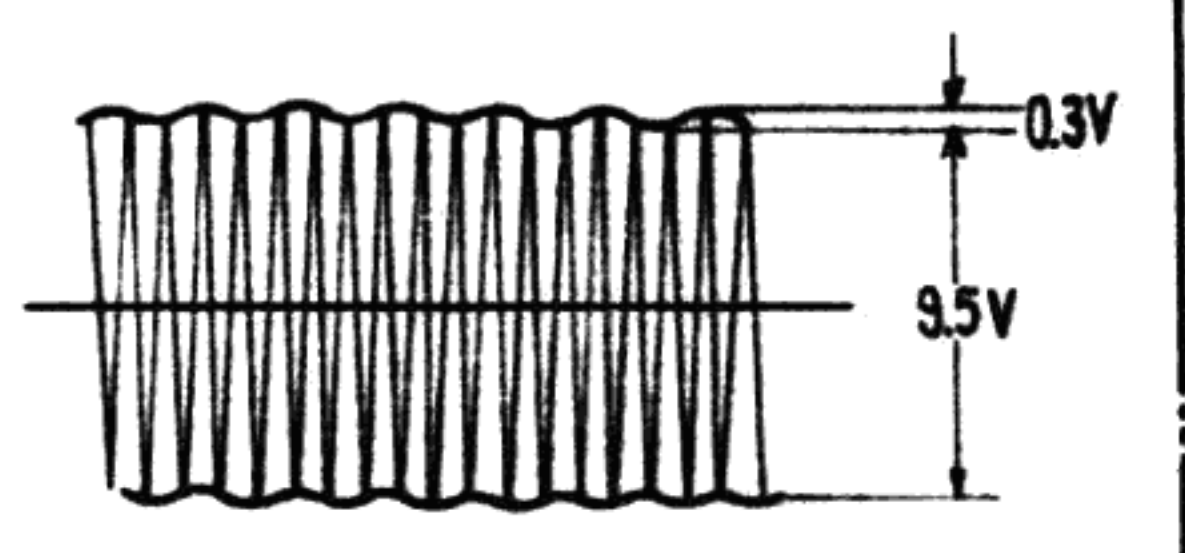

⑥-⑦

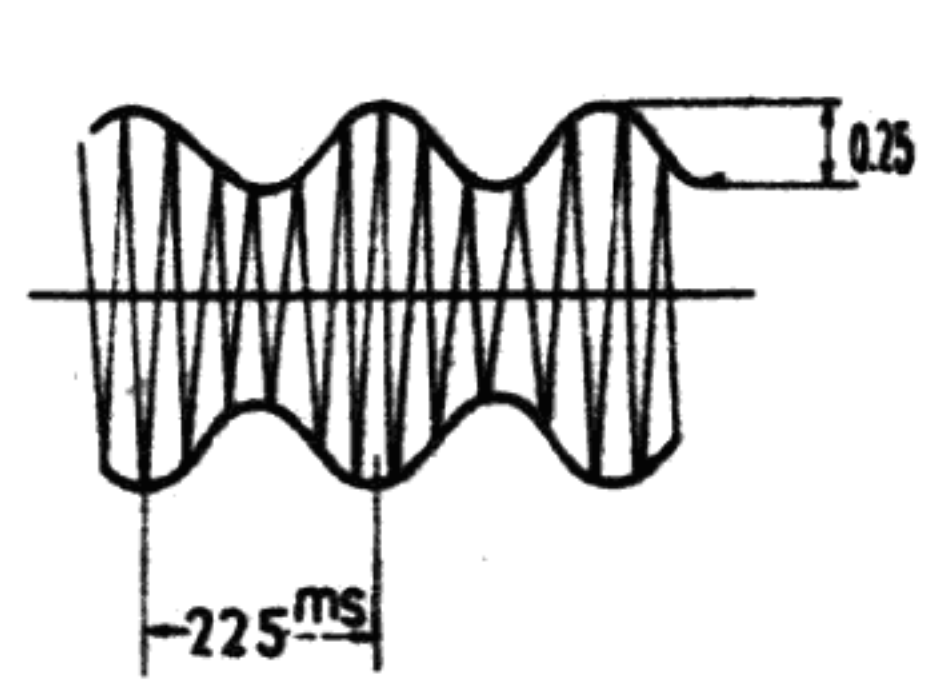

④-⑩

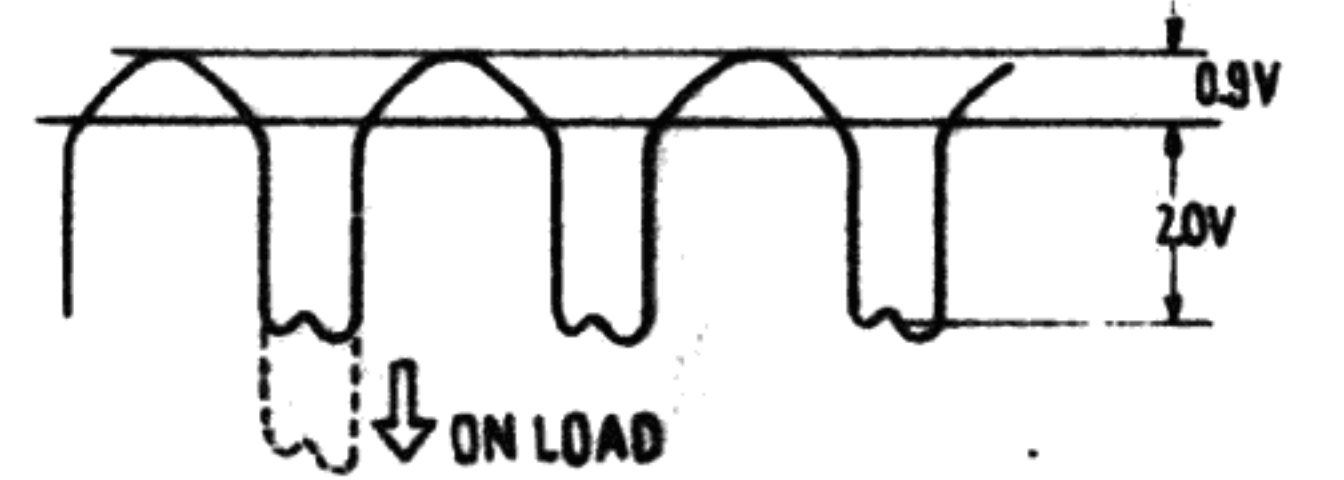

CIRCUIT BOARD

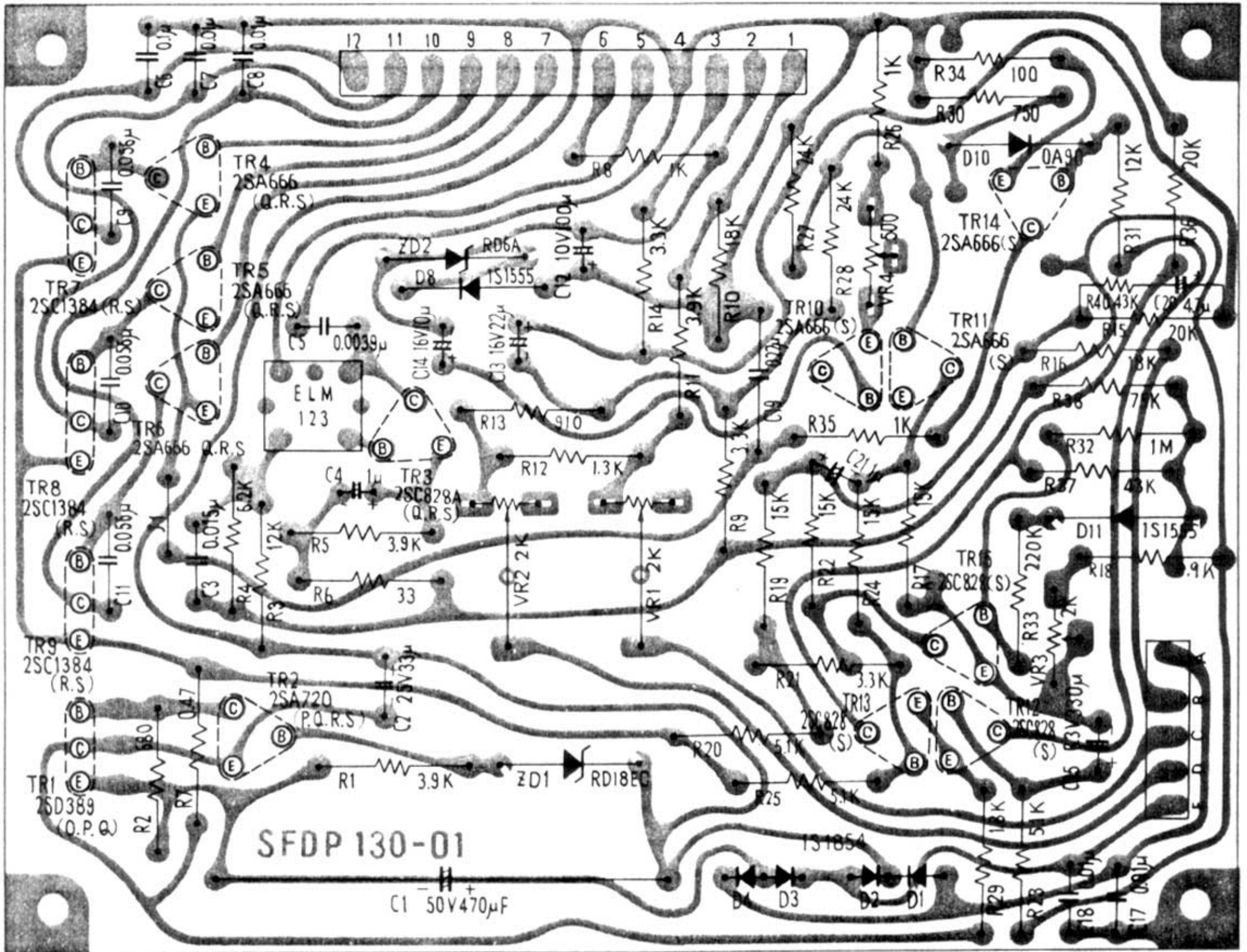

Circuit Plate

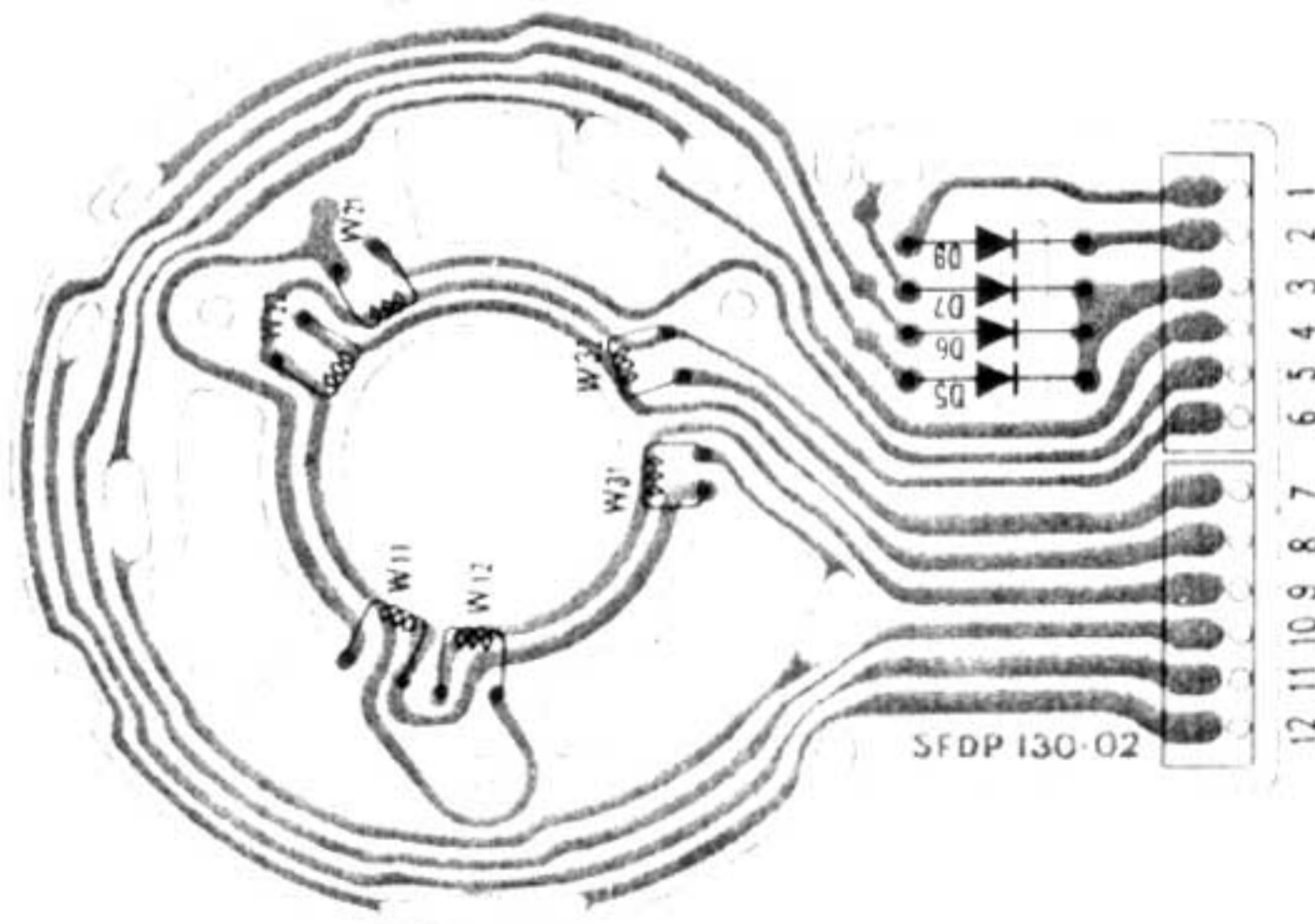

Motor

TROUBLE SHOOTING GUIDE

* Except when checking voltage, disconnect the power cord before repair without fail.

TROUBLE	CAUSE	REMEDY
Turntable Speed A. Switching on does not cause turntable to rotate.	Remove back cover and, using DC voltmeter, check printed base voltage: 1. No output of constant-voltage circuit (between Tr1 collector and 4) is found. (1) No output on secondary of transformer. * Cord disconnected. * Soldered improperly. * Fuse disconnected. * Power transformer defective. (2) Output found on secondary of transformer. * Constant-voltage circuit parts (ZD1, Tr1, Tr2) defective. 2. Output of constant-voltage circuit is 17~20V. * 3-phase switching circuit (Tr4 ~ Tr9), oscillator circuit (Tr3) defective. * Tr14 defective. 3. Power Switch is not ON. * Micro switch defective. 4. Speed selector switch defective. * Contact faulty * Soldered improperly.	<ul style="list-style-type: none"> * Replace cord. * Solder securely. * Replace fuse. * Replace power transformer. * Replace printed base assembly. * Replace printed base assembly. * Replace micro switch. * Replace speed selector switch. * Solder securely.
B. Turntable speed too fast.	1. Constant-voltage output is not 17~20V. * Constant-voltage circuit parts (ZD1, Tr1, Tr2) defective. 2. Constant-voltage output is 17V~20V. * Diodes D8, D9, ZD2 defective. * Diodes D5, D6, D7 shorted. * Speed maladjusted.	<ul style="list-style-type: none"> * Replace printed base assembly. * Replace printed base assembly. * Replace motor. (Stator frame Ass'y). * Adjust semi-fixed resistor VR1 & VR2.
C. Turntable speed too slow.	1. Constant-voltage output is not 17~20V. * Constant-voltage parts (ZD1, Tr1, Tr2, defective.) 2. Constant-voltage output is 17~20V. * Diodes D8, D9, ZD2 defective. * Speed unadjusted.	<ul style="list-style-type: none"> * Replace printed base assembly. * Replace printed base assembly. * Adjust semi-fixed resistor VR1 & VR2.
D. Turntable speed varies too much.	<ul style="list-style-type: none"> * Trouble in 3-phase switching circuit. 	<ul style="list-style-type: none"> * Replace printed base assembly.
E. Turntable, after stopped by hand, will not turn or starts turning but will stop soon.	<ul style="list-style-type: none"> * 3-phase switching circuit defective. 	<ul style="list-style-type: none"> * Replace printed base assembly.
F. Operative at only one of two speeds. (33-1/3 rpm, 45 rpm)	<ul style="list-style-type: none"> * Selector switch defective. * Lead disconnected or unsoldered. * Contact of Vr1, Vr2 insufficient. 	<ul style="list-style-type: none"> * Replace selector switch. * Replace lead, or solder securely. * Replace printed base assembly.
G. When actuating, turntable speed is unsteady for along time.	<ul style="list-style-type: none"> * Semi-fixed resistor VR3 & VR4 unadjusted. 	<ul style="list-style-type: none"> * Make it become 50mV at both ends of C15 with semi-fixed resistor VR3. * Make it become 2.2V at both ends of R38 with semi-fixed resistor VR4.
Noise Offensive noise is heard.	<ul style="list-style-type: none"> * Power transformer makes loud noise of vibration. * Broken part of rotor magnet or iron chips attracted by magnet and rubbed by motor case. 	<ul style="list-style-type: none"> * Replace power transformer. * Remove iron chips.

SL-1300

COMPONENT PACKING PROCEDURE

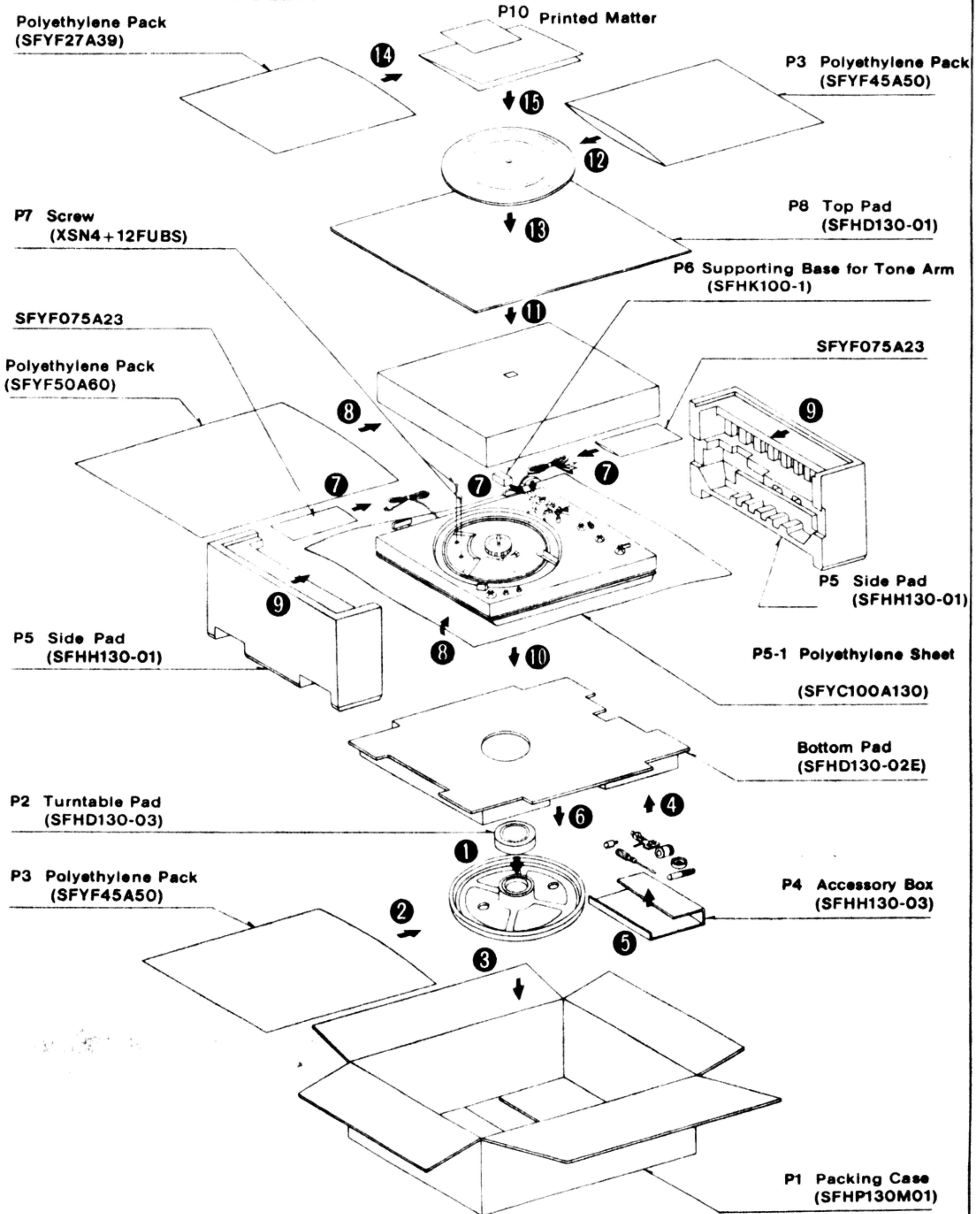

EXPLODED VIEW OF DIRECT DRIVE PLAYER MODEL SL-1300

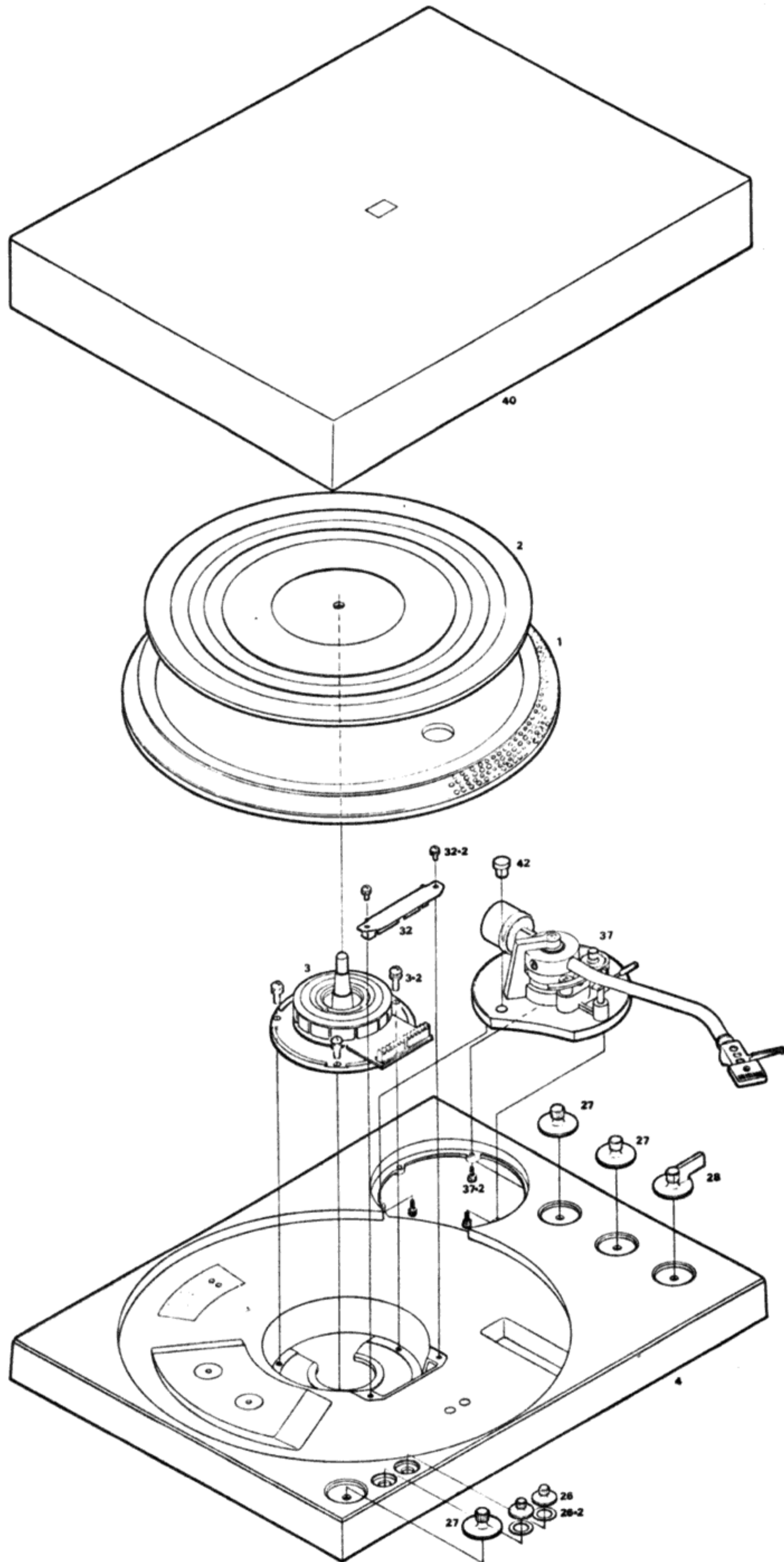

EXPLODED VIEW OF DIRECT DRIVE PLAYER MODEL SL-1300

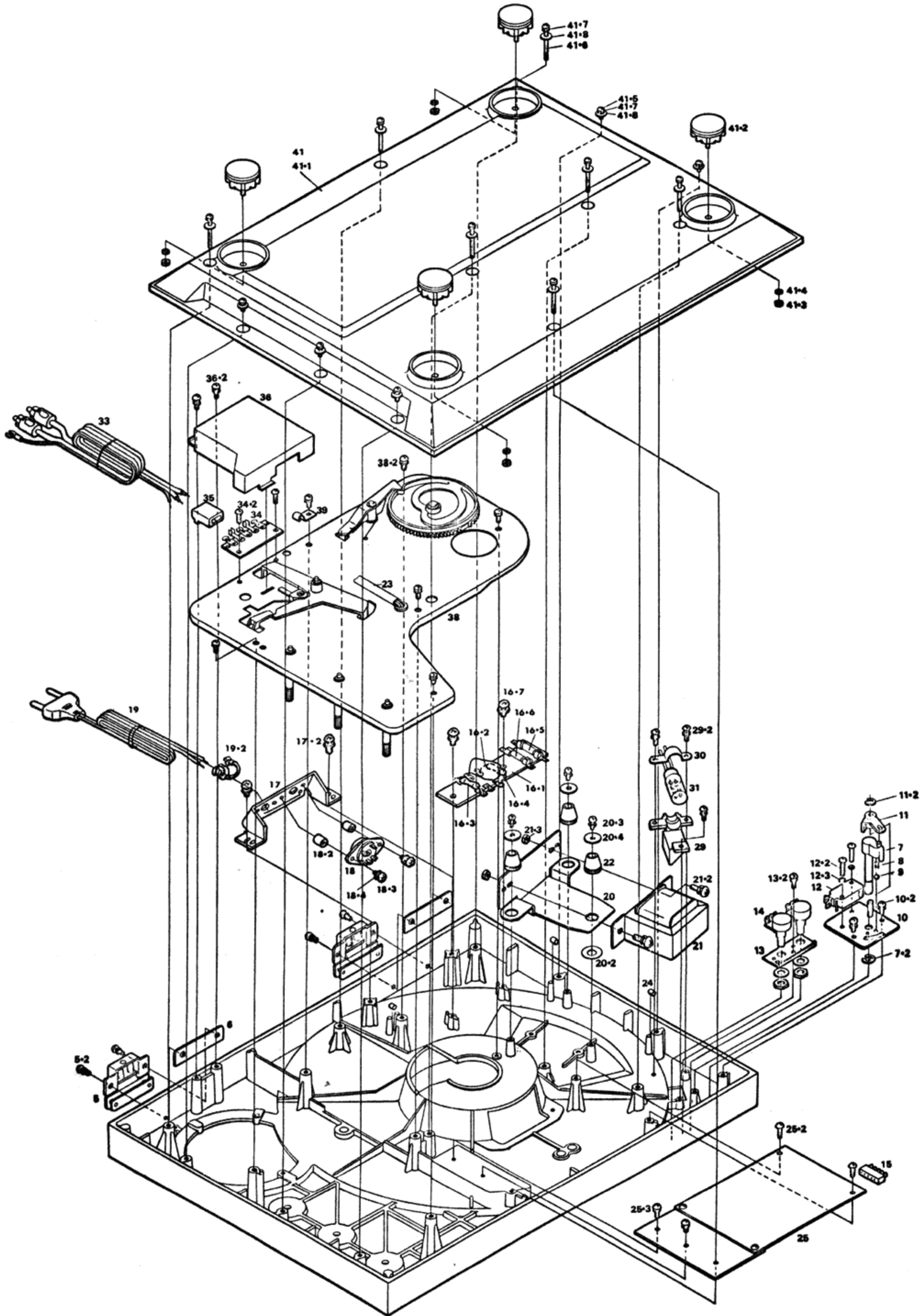

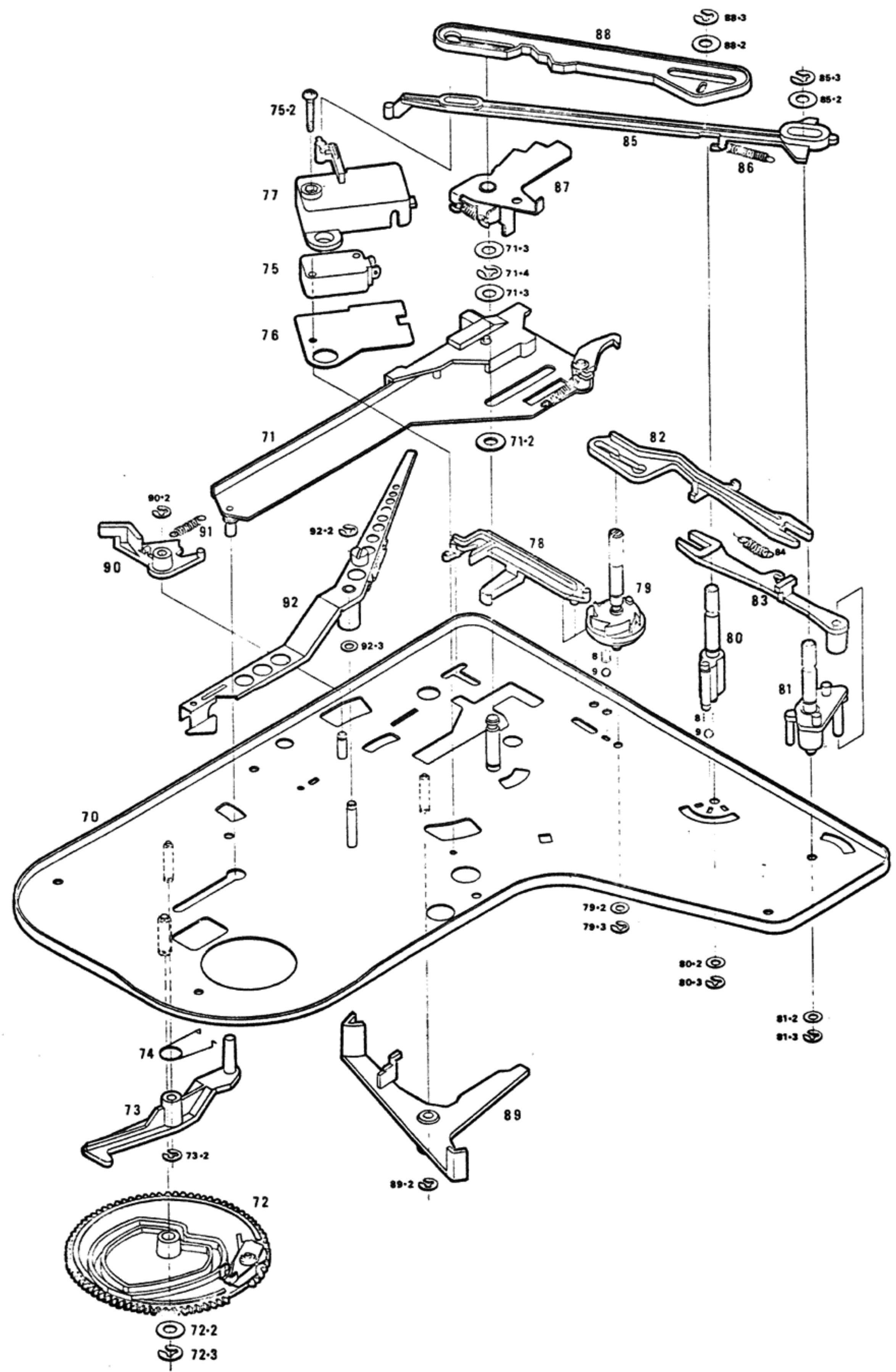
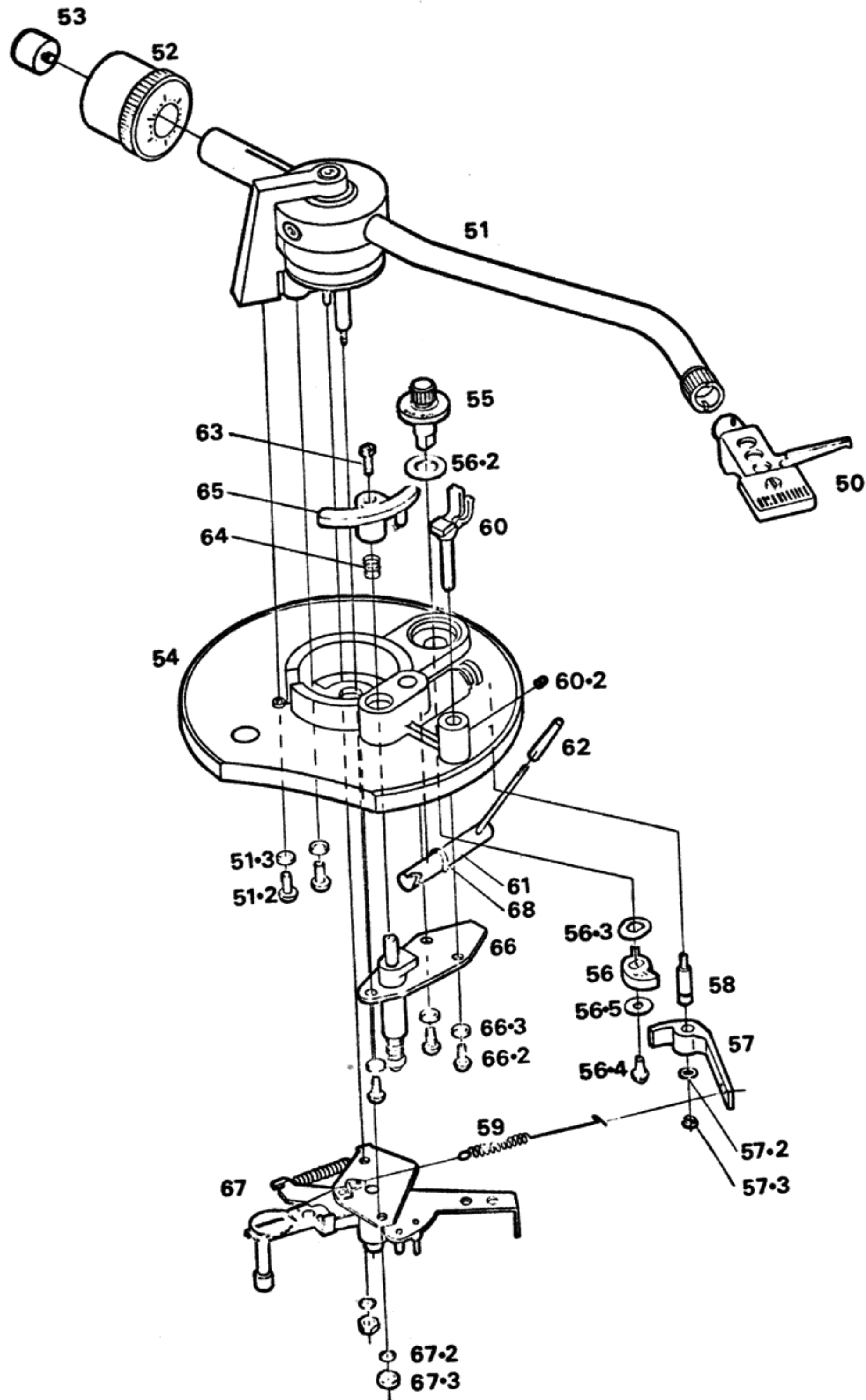

PARTS LIST

NO.	PART NO.	DESCRIPTION	Q'TY	NO.	PART NO.	DESCRIPTION	Q'TY
1	SFTE130-01A	Turntable platter	1	19-3	SFER1D	Ground terminal (for Australia)	1
2	SFTG120-01	Turntable sheet	1	20	SFUP130-03	Mounting plate for transformer	1
3	SFMZ130-01Z	Stator frame assembly	1	20-2	SFXW120-02	Washer for mounting plate	1
3-2	XYN4+C8FUS	Screw for stator frame	3	20-3	XYN3+C6FUS	Screw for mounting plate	3
4	SFAC130X01	Player case	1	20-4	SFXW750-1	Washer for mounting plate	3
5	SFAT120-01E	Hinge assembly	2	21	MPT-006	Transformer	1
5-2	XYN3+C10FUS	Screw for hinge assembly	4	21-2	XYN4+8FUS	Screw for transformer	2
6	SFUP120-01	Mounting plate for hinge	2	21-3	XNG4HFUS	Nut for transformer	2
7	SFUM130-02	Switch cam assembly	1	22	SFGC827M01	Cushion rubber for transformer	3
7-2	SFUM130-02	E-shaped ring	1	23	SFEB6BT130	Vinyl tube for transformer and mechanism black	2
8	SFGA130-11	Click spring	1	24	SFGZ120-02	Clamping rubber for read wires	4
8	SFQA130-11	Click spring for repeat cam	1	25	SFDP130-01A	Circuit plate assembly	1
8	SFQA130-11	Click spring for select cam	1	25-2	XSN3+6FUS	Screw for circuit plate assembly	2
9	SFYB-5-32	Steel ball	1	25-3	XYN3+C6FUS	Screw for circuit plate assembly	2
9	SFYB-5-32	Steel ball for repeat cam	1	26	SFKT130-01A	Variable pitch control knob assembly	2
9	SFYB-5-32	Steel ball for select cam	1	26-2	SFUZ130-03	Felt for variable pitch control knob	2
10	SFUP130-07E	Switch plate assembly	1	27	SFKT130-03A	Operation knob assembly	3
10-2	XYN3+6FUS	Screw for switch plate	2	28	SFKT130-05A	Start lever assembly	1
11	SFUM130-03	Change lever for switch	1	29	SFUM130-01	Neon lamp base	1
11-2	XUC3FY	E-shaped ring	1	29-2	XYN3+C6FUS	Screw for neon lamp	2
12	AM9620-44	Micro Switch	1	30	SFUP130-05	Neon lamp holder	1
12-2	XTN3+16BFU	Screw for micro switch	2	31	SFDN130-01A	Neon lamp assembly	1
12-3	XWA3BF	Spring washer	2	32	SFUP130-06	Print base cover	1
13	SFUP130-01	Mounting plate for variable resistor	1	32-2	XYN3+C6FUS	Screw for print base cover	2
13-2	XYN3+C6FUS	Screw for mounting plate	1	33	SFDH120-01	Phono cable	1
14	EVHB0AK15B52	Variable resistor	2	34	SFER130-01	Terminal strip for phono cable	1
15	SFDJ12805S	5-pin connector	1	34-2	XTN3+6BFU	Screw for terminal strip	3
16	SFER130M01A	Terminal strip assembly	1	35	SFGP130-01	Cord clasper for phono cable	1
16-1	SFER130X01E	Terminal strip	1	36	SFUP130-08	Shield cover	1
16-2	ECQE10473MZ	Capacitor	1	36-2	XYN3+C6FUS	Screw for shield cover	2
16-3	ERG2ANJ472	Carbon film resistor	1	37	EPA-130	Tonearm assembly	1
16-4	ERD12TK4R7	Carbon film resistor for strobo illuminator	1	37-2	XYN3+C10FUS	Screw for tonearm assembly	3
16-5	XBA2C10NSS	Fuse	1	38	SP-130	Automatic mechanism assembly	1
16-6	XBA2C03TROU	Fuse	1	38-2	XYN3+C6FUS	Screw for automatic mechanism assembly	6
16-7	XYN3+C6FUS	Screw for terminal strip assembly	2	39	SFUP154A1	Clasper for AC power cord	1
17	SFUP130X04	Fixing plate for AC power cord	1	40	SFAD130M01A	Dust cover assembly	1
17	SFUP130L04	Fixing plate for AC power cord (for Australia)	1	41	SFAU130-01A	Bottom cover assembly	1
17-2	XYN3+C6FUS	Screw for fixing plate	2	41-1	SFAU130-01	Bottom cover	1
18	SSRA1	AC Line voltage selector	1	41-2	SFUZ130-01A	Audio insulator assembly	4
18-2	SFX0130X01	Spacer for AC Line voltage selector	2	41-3	XNG3HFUS	Nut for audio insulator	4
18-3	XSN3+12FVS	Screw for AC Line voltage selector	2	41-4	XWA3BF	Spring washer for audio insulator	4
18-4	XWA3BFM	Spring washer for AC Line voltage selector	2	41-5	XSN3+10FV	Screw for bottom cover	5
19	SJAA3	AC Power cord	1	41-6	XSN3+35FV	Screw for bottom cover	7
19	SJA51	AC Power cord (for Australia)	1	41-7	XWA3BF	Spring washer for bottom cover	12
19-2	SFHK040L	Bushing for AC power cord	1	41-8	SFXW120-01	Washer for bottom cover	12
19-2	SHR113	Bushing for AC power cord (for Australia)	1	50	SFP-CC13001K	Head shell assembly	1